

OBSTA-XE-R-24

Xenon medium intensity type B compliant with ICAO medium intensity type B and compliant with FAA L-864 including a flashhead and a power supply (300m max)

P/N : **113821**

The OBSTAFASH Xe red or white medium intensity is a flashing obstruction light dedicated to day and night marking of any obstacles. The OBSTAFASH Xe is compliant with ICAO medium intensity type A, FAA L865/L866 flashing lights. The use of white strobe medium intensity during day time eliminates the need to paint the obstacle with aviation red and white stripes.



Patents: **EP 1966535B1 & US 7816843**

Key Points

Flashhead

- 2 xenon flash tubes in redundancy
- Enveloppe and optic in glass
- No tools required to open the flashhead
- Aluminium body
- All electronic in the power supply (300m max)

Power supply

- 'Weather tight' stainless steel 316L power cabinet enclosure with safety interlock switch
- Long life dry capacitors
- 'Plug-in' modular construction
- Alarm relay and synchronisation card provided
- to be used with photocell 24Vdc P/N100754 and interconnecting cable P/N113805 (max length 300 meters) between flashhead and power supply
- in option wireless GPS interface for synchronisation P/N113746 and 24Vdc battery cabinet P/N113505

Electrical Characteristics		
Power supply		24VDC +/-10%
Average power consumption		140W
Mechanical Characteristics		
Operating temperature		-30/+60°C
Size of the light		494mm (height) x 394mm (over diameter)
IP degree		IP65 for power cabinet in vertical position
Weight		18kg for flashhead, 24kg for power cabinet
Wiring		Entry of cable by glands nickel plated brass and connection by terminals
Wire cross section		from 1 to 4 mm ²
Attachment		6 mounting holes dia.16mm, dia.337mm circle

Mechanical Characteristics

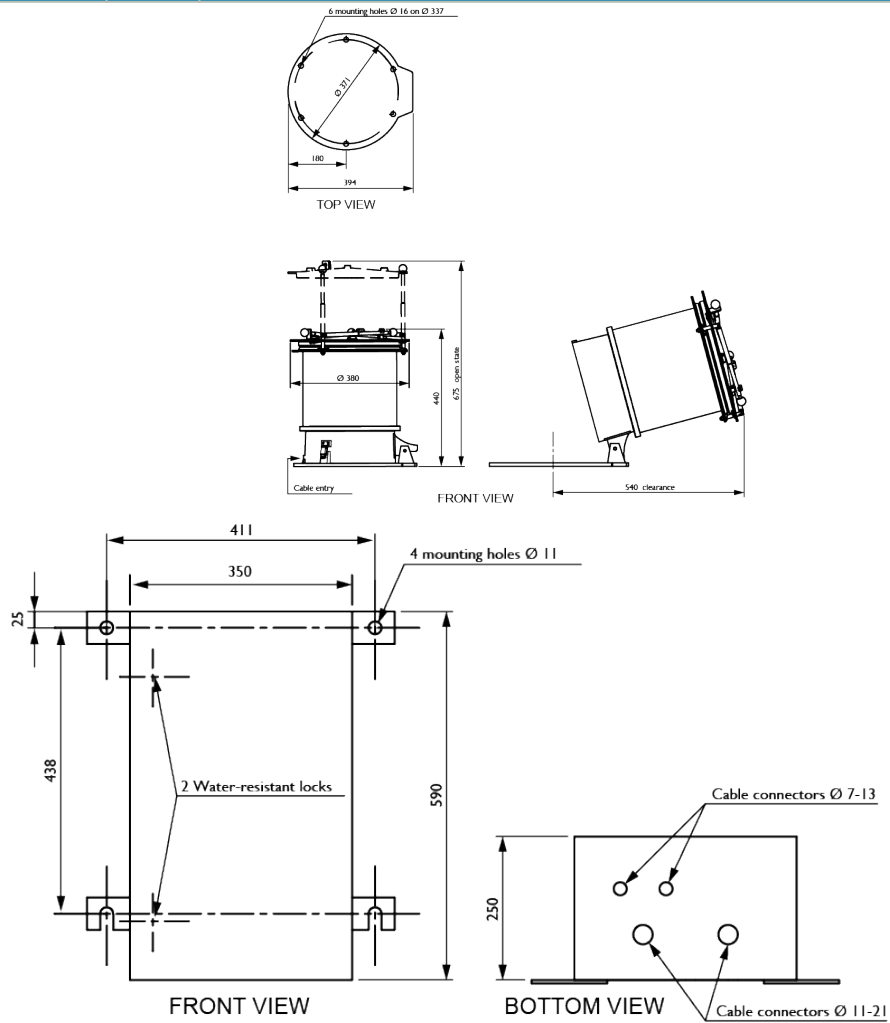

Photometric Characteristics		
Effective light output night mode at 0° on site		2000cd (red)
Color night time		Red
Vertical beam spread		>3°
Horizontal beam spread		360°
Flash per minute		20, 40 or 60 flashes per minute
Standards		
Standards compliance		ICAO annex 14 chapter 6, FAA (AC 150/5345-43G) with alarm monitoring